

Home Automation **Server**

User manual

EN

V 2.0.0

Product	Item number
Home Automation Server	PNX22-10004





This instruction contains the most important information for operating the Home Automation Server in a safe manner. Please study this manual carefully before working with the device. This applies to all persons who come into contact with the device.

The product names mentioned in this document may be brands or registered trademarks of their respective owners. These are not explicitly labeled with “™” or “®”.

© PEAKnx GmbH
Leydheckerstraße 10
64293 Darmstadt
Germany

www.peaknx.com
info@peaknx.com
Document version: 2.0.0
Date: 21.05.26

Warning symbols and signal words used in this manual

 Warning	Obey warning to avoid death or serious injury
 Caution	Obey instructions to avoid personal injury or damage to property
Note	Instructions and facts to be followed
Tip	Additional, useful hints

Important safety instructions, please read before installation!

 **Warning**

The device can carry dangerous voltages if improperly installed!

- Installation and start-up may only be carried out by specially trained personnel (qualified electricians)

 **Caution**

Avoid damage to the Home Automation Server!

- Only use the Home Automation Server in perfect condition, as well as in accordance with its intended use, in a safe and hazard-aware manner and in compliance with this manual!
- Do not make any changes, attachments or conversions to the device without the manufacturer's permission!
- In particular, have faults that could impair safety immediately eliminated!

Note: Opening the Home Automation Server voids the warranty

Contents

Legal notes	2
Warning symbols and signal words used in this manual	3
Important safety instructions, please read before installation!	3
1 Target audience	5
2 Intended use	5
3 Product description	6
3.1 Software	6
3.2 Device elements	7
4 Important notes on safety and handling	8
5 Installation and start-up	9
6 YOUVI setup: Procedure	10
6.1 Preparing the ETS project	11
6.2 Project import	12
6.3 Setting up the visualisation	17
6.4 Creating the dashboard	18
6.5 Creating a client backup	19
7 Option: Installing and setting up add-ons	19
8 Establishing a connection to the KNX network	20
9 Notes on the bus monitor and IP router	21
10 Saving the YOUVI project	21
11 Technical support	21
12 Technical data	22
Subject to change without notice	23
Conformity	23
Disposal notes	23
Declaration of conformity	24

1 Target audience

These instructions are intended to explain basic aspects of the installation, commissioning, operation and maintenance of the Home Automation Servers. Depending on the use phase, this manual is aimed at other target groups:

Commissioning

- Installation in the control cabinet may only be carried out by qualified electricians. Basic knowledge of electrical and KNX installation as well as ETS project planning is assumed.

Operation

- Instructions for using the software are intended for unskilled users.

Repair

- Under no circumstances carry out repairs to the unit yourself! If damage should occur to the device, please contact our technical support immediately, see *11 Technical support*.

2 Intended use

The Home Automation Server serves as a cross-room control unit for the entire KNX installation. It establishes the connection between the IP and KNX network and provides the visualisation for connected clients. The device must be operated in accordance with the technical data and instructions in this manual. Keep the device away from moisture, dirt and dust to prevent damage to the device.

The following applications are part of the intended use:

- Control unit for all connected IP and KNX network devices.
- Operation in a control cabinet, observe the ambient conditions, see *12 Technical data*.

The following applications are NOT part of the intended use:

- Operation in systems requiring special monitoring, in safety-relevant areas or in hazardous areas
- Operation under ambient conditions that do not comply with the specifications regarding temperature and air humidity. These include
 - Outdoor operation
 - Operation in environments with high dust and dirt exposure
 - Operation in environments with high vibration exposure
- Operation in a moving environment (e.g. mobile homes)
- Operation in vessels
- Use with a third-party bus coupler

3 Product description

The Home Automation Server enables secure and flexible building control. It provides the YOUVI visualisation for all connected end devices, which can then be controlled independently of the platform via Apple Home, Alexa or Aragon, for example.

An app for control within the smart home is also included. The mobile app runs on iOS or Android devices. YOUVI add-ons can be used to extend the functional scope of YOUVI with additional features such as voice control or door communication.

Note: *The range of functions of the smartphone app is limited compared to the visualisation (Windows app). You can find out which functions the mobile app supports in the YOUVI range of functions at www.peaknx.com/Downloads > YOUVI.*

3.1 Software

Note: *The server can only be operated with the pre-installed YOUVI software.*

The YOUVI Basic visualisation software included in the scope of delivery is used to control KNX devices such as sockets, switches, lights, dimmers, RGB lights, heaters, ventilation, blinds and shutters. In addition to the visualisation and IP router, the scope of delivery also includes a bus monitor that can record and filter KNX traffic.

In addition to the basic functions for controlling KNX devices, YOUVI can be expanded via modules for IP camera connection, door communication via SIP, creation of logic functions, remote control via app when away from home and voice control. YOUVI bridges for Sonos, trivum, neoom, Ikea, Phillips Hue or Netatmo are available to connect additional smart home devices from other manufacturers. All current YOUVI add-ons are available in the shop at www.peaknx.com > Shop > KNX visualisation > YOUVI.

Tip: *Further information on YOUVI can be found in the YOUVI help, which you can access in YOUVI under the “?” icon. Here you will also find the current range of functions of the software under: Visualization > Functional scope.*

3.2 Device elements

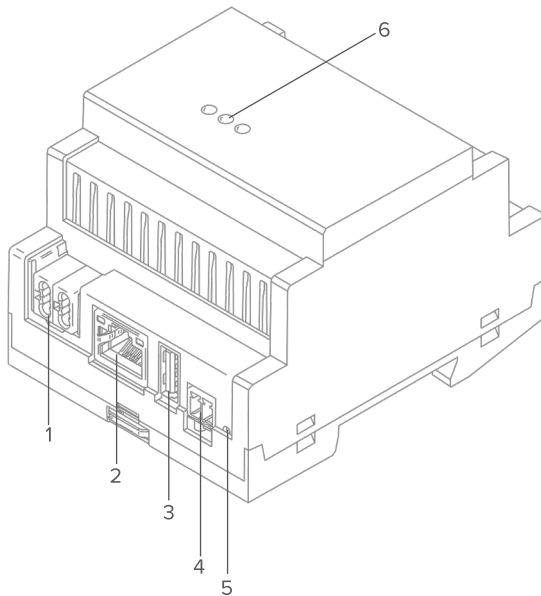

Position	Description
1	Power supply 8 - 30 V DC
2	1 Gbit Ethernet
3	USB 2.0
4	KNX-Connection
5	Reset / Restart button
6	KNX / status / power LED

Note: If you press and hold the **reset/restart** button for approx. 5 seconds, until the status LED changes from red to flashing red, the device will be reset to factory settings; otherwise, the Home Automation Server will only restart. The status LED will continue to flash until the reset process is complete. The server will then restart.

LED display

KNX status	LED colour	Meaning
No KNX bus power supply / cable disconnected	● RED solid	
Power detected, initialisation in progress	● ORANGE solid	
KNX operational, normal bus load	● GREEN flashing	Bus load < 80 %
KNX operational, high bus load	● ORANGE flashing	Bus load ≥ 80 %

4 Important notes on safety and handling**Warning**

The Home Automation Server may only be installed and commissioned by qualified electricians!

**Warning**

Observe the national regulations applicable in your country regarding installation, functional testing, repair and maintenance of electrical products!

- Observe the "Five Safety Rules" (DIN VDE 0105, EN 50110) and apply them correctly:
 - Disconnect mains
 - Prevent reconnection
 - Test for absence of harmful voltages
 - Ground and short circuit
 - Cover or close off nearby live parts
- Before installation, make sure that all connecting cables of the device are undamaged.

5 Installation and start-up

Proceed as follows to set up the server:

- Connect the server in the control cabinet to a power supply. Required supply voltage: 8-30 V DC. Recommendation: Meanwell HDR-15-24
- Connect the server to the network, cabling standard at least CAT 5.
- Use your router or an IP scanner to find the IP address of the server in the network.
- Enter the IP address of the server and the port “31228” in the browser, e.g.: 10.11.12.67:31228

Note: If no fixed IP address has been assigned beforehand, you can also connect directly to the server (without a network router) using a network cable and access it via `pnx-has.local`.

YOUVI Configuration opens:

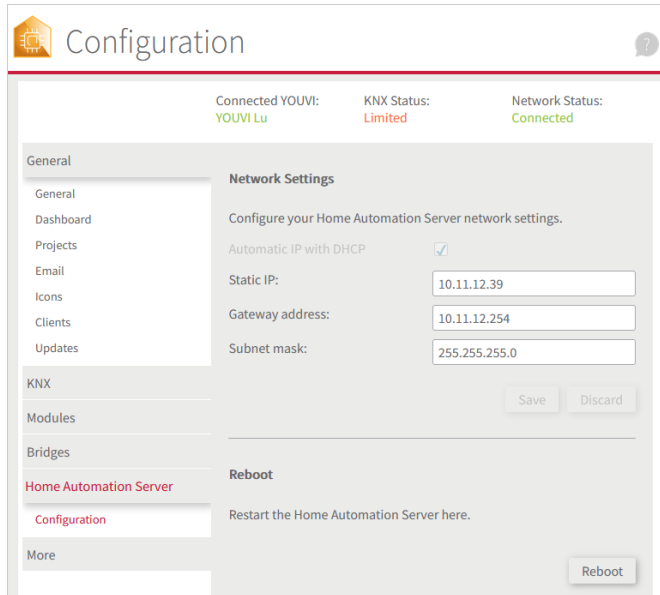

- You can view the IP address under the “Home Automation Server” tab. The IP address is initially assigned automatically. You can then change this.

Tip: Further details on the subject of setup and commissioning can be found in the *YOUVI Help* under the menu item *YOUVI Configuration*, which you can access via the “?” icon.

6 YOUVI setup: Procedure

After commissioning, set up the visualisation. It is assumed that all KNX actuators have already been parameterized via the ETS. At the end of the setup, the configuration is saved in a YOUVI backup.



Instruction videos:



Setup





ETS-Import



ETS-Import: <https://cavok.peak-group.de?embedKey=0vk5DI>
Setup: <https://cavok.peak-group.de?embedKey=Q1rHer>



The visualisation is created in YOUVI in four steps:

1. Customizing the ETS project
2. Upload the ETS project to YOUVI
3. Checking the parsing result in the YOUVI project editor
4. Setting up the visualisation: Dashboards and other widgets

6.1 Preparing the ETS project

To guarantee a successful readout of the project, please check the following points:

Note: Work with the ETS 5 or 6.

- Room allocation
 - The room assignment of the devices (light, shutter, etc.) is realized via push buttons or ETS functions  that are located in the corresponding room. If push buttons for a device are located in multiple rooms, or if there are no push buttons for certain devices, use ETS functions  to precisely assign the rooms. The push buttons or functions share at least one group address with the actuator in order to implement the room assignment of the device.
 - Make sure to always assign only one device to one function.
 - Create a control cabinet in the rooms for sub-distribution.
- Device naming
 - Group address names are used in YOUVI as device names, so name them comprehensible, for example: “ground floor living room ceiling light (s)”.
 - Give group addresses of a device identical names, only adding a word or different letters at the end to distinguish them, such as “feedback”, “switch”, or others. These additions will be filtered out by YOUVI and will not appear in the visualisation. You will find more on reading out the device names and naming with voice control in the *YOUVI Help > Tips for your ETS project*.
- Device parsing
 - Use the table in *YOUVI Program Help > Tips for your ETS project*, to make devices recognizable for YOUVI. Here you can see which group objects and data point types must be at least present at the actuators for device identification.
 - Define active feedback for the devices.
- Export
 - Export the project as a knxproj file.

Note: Make sure that you do not use any spaces or special characters in the project name to avoid errors during processing.

6.2 Project import

- After you have viewed your ETS project, export it as a knxproj file.
- Go to *YOUVI Configuration > General > Projects* and select the arrow symbol:

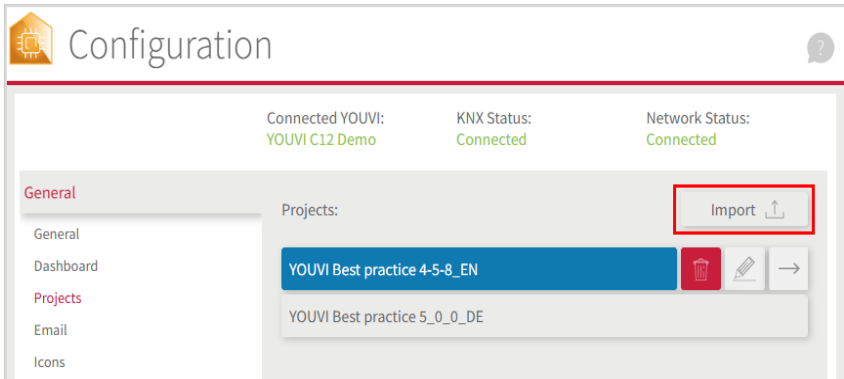

- Select the project file for the upload.
- During the upload, you will be asked whether you want to activate device parsing. Select the „Switch on device parsing“ checkbox here and confirm. If you do not tick the box, only group addresses will be imported. All devices must then be created manually.
- The upload may take a few minutes.
- After a successful upload, click on the arrow pointing to the right to open the project editor:

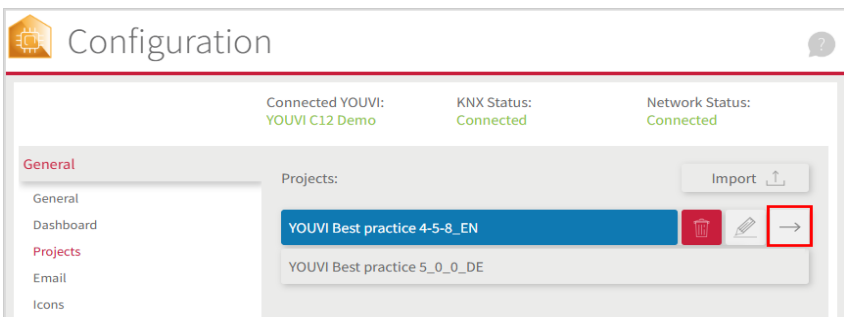

Note: To change the project name, click the pencil icon. To delete the project, use the trash icon.

- In the project editor, select the project on the left-hand side and you will see a list of all the devices read out:

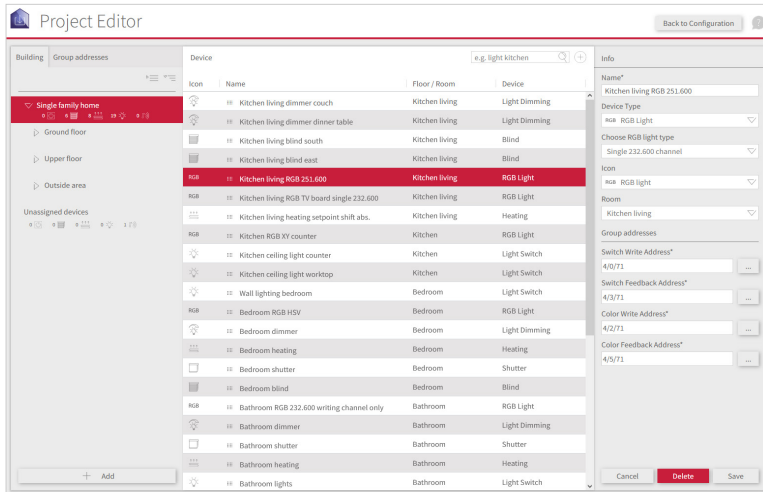

- Click on the respective device in the centre area to check the name, device type, icon, group addresses and room assignment in the right-hand column and edit them if necessary.
- Go through all devices in this way.
- Change the building structure by selecting the relevant building parts on the left and editing them on the right. Or create new building parts using the „Add“ button at the bottom left.

- The “Not assigned” category is displayed under the building structure on the left-hand side.
- In this category, you will find all devices that have been detected but could not be assigned to a room. If you have already gone through all the devices, this should be empty.:

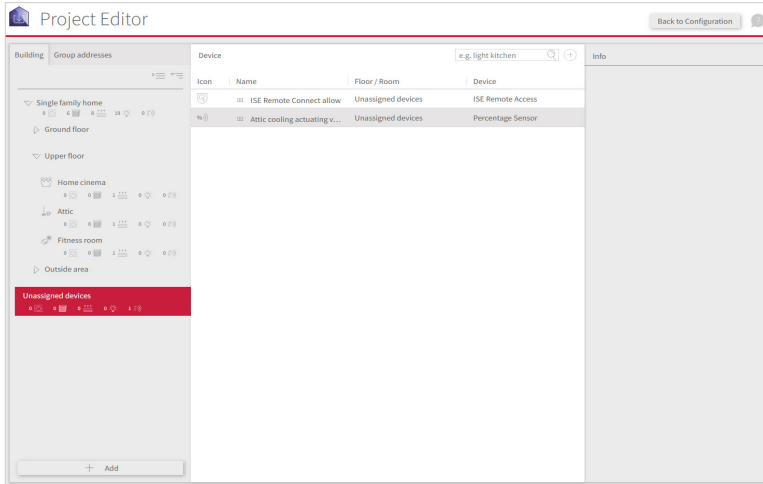

- Select the devices in the list and change the corresponding room assignment in the info area on the right-hand side if devices are to appear in the visualisation. Devices in the „not assigned“ room are not displayed in the visualisation when edit mode is switched off.
- Now change the tab at the top left to “Group addresses“. Expand the individual groups. Group addresses that could not be assigned to a device are marked with an icon . You can now create these devices manually in the project editor by clicking on the plus button next to the search field:

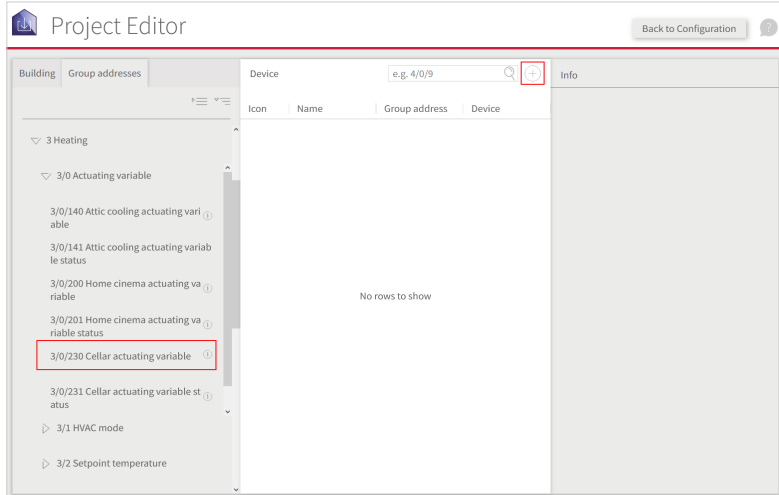

- The following dialogue then opens:

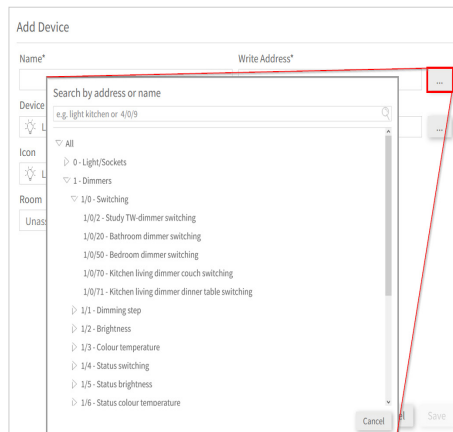

- Enter the name, device type and room on the right. You will find a selection of all group addresses if you click on the three dots next to the group address field. Select the required group addresses and confirm with “Save”. The corresponding group address is now no longer highlighted. When you click on the group address, the device created is now displayed:

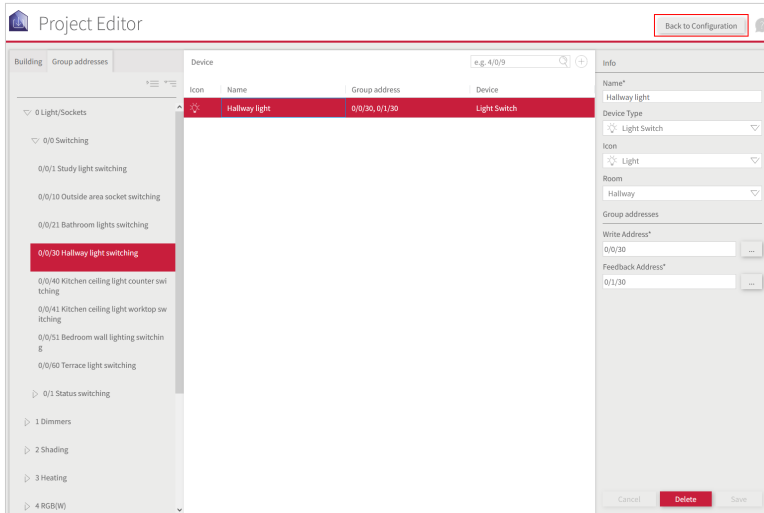

- The “Back to configuration” button takes you back to the complete overview of the application.

6.3 Setting up the visualisation

- On the dashboard page, select the red icon above “Visualization”. The visualization opens on the settings page.

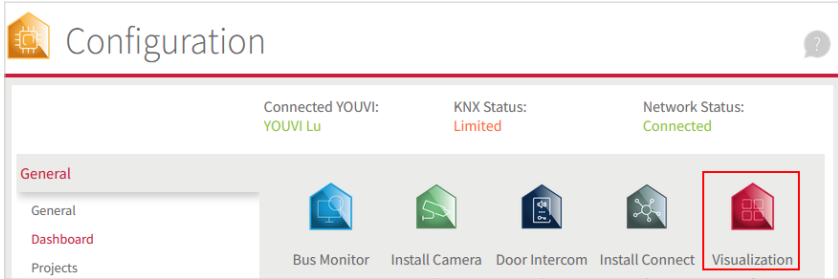

- In Settings > Connection settings, you can see which YOUVI server you are connected to. Red text indicates a connection. Select the desired server and check the box if you are not yet connected to a server. In special cases, you can also add the YOUVI server manually by selecting “Add” and entering the IP address of the device.
- Switch on the edit mode. Edit Mode
- Switch to the building overview by selecting the house icon in the bar on the left.







- The imported project is shown in the visualization.

- The “not assigned” room contains all devices that YOUVI could not clearly assign to a room. It is only visible in edit mode.
- If you would like to create scenes, specific group functions or devices that are not yet supported in the project editor, click on the “Add” button in the building overview and select the desired element to create it.
- Once all devices and functions have been created, deactivate the edit mode.
- Setting timers: Switch to any room and click on the cogwheel on any device to set timers.

Note: *In the event of problems with the visualization, you can find the YOUVI program help under Settings > YOUVI help.*

6.4 Creating the dashboard

The dashboard of the visualisation gives you an overview of your favourite functions. To create it, the most important functions are simply “pinned” to it.

- Switch back to the visualisation and make sure that the Edit mode is switched on.
- Switch to the room overview.  Open each room and select the dashboard icon  on the respective tile to add it to the dashboard.
- The dashboard icon next to the room name adds the room to the dashboard.
- The group tiles on the Devices Templates page  can also be added to the dashboard.
- Now switch to the dashboard page.
- Expand tiles by using the arrow icon  on each tile. In some cases, expanding the tile also gives you additional functions. This is the case for heating, blinds, weather station or room buttons.
- On the dashboard you can move the tiles by drag & drop.
- During this process the grid always fills from left to right. Use placeholders (“+ placeholder“ button) to fill empty spaces. For example, you can fill the end of a row with placeholders so that the new device tile can be pinned to the next row.
- You can create up to five different dashboard pages, each with a choice of three dashboard layouts (“Layout” button).
- If you have set up IP cameras, a door station or a sound system, add a corresponding widget via “+ camera” “+door station” etc.
- To add web pages to your dashboard, select “+ Web Widgets”.

- At the end, turn off the Edit mode again.
- Under *Settings* > *YOUVI Settings* click “Activate” under “Autostart” to open the visualisation automatically after a restart.
- In this menu you can additionally select temperatures for the title bar as well as the light or dark theme of the visualisation.

6.5 Creating a client backup

- Under *Settings* > *YOUVI Settings* you will find the item “Backup”. Click on “Save”.
The backup of the visualisation is created.
- Name the backup for unique client association and place it in the created backup folder on the server.
- Further information on backups can also be found in the program help.

7 Option: Installing and setting up add-ons

If you want to use add-ons permanently, you need to purchase a licence once. Additional functions available include, for example, a logic editor, IP camera widgets or voice control. The latest add-ons can be found on the *YOUVI Configuration Dashboard* page.

📘 **Tip:** For more information on how to set up the add-ons, see the program help topics “Modules” or “Bridges”.

8 Establishing a connection to the KNX network

Note: YOUVI cannot be used with KNX/USB connectors or KNX/IP routers from third-party manufacturers.

The KNX status in **YOUVI Configuration** shows you if a KNX connection has been established.

- After the YOUVI installation, the KNX status should be “Connected”, as shown in the picture.
- If the KNX connection cannot be established, go to *KNX > KNX Connection* in YOUVI Configuration and connect manually to the displayed interface.

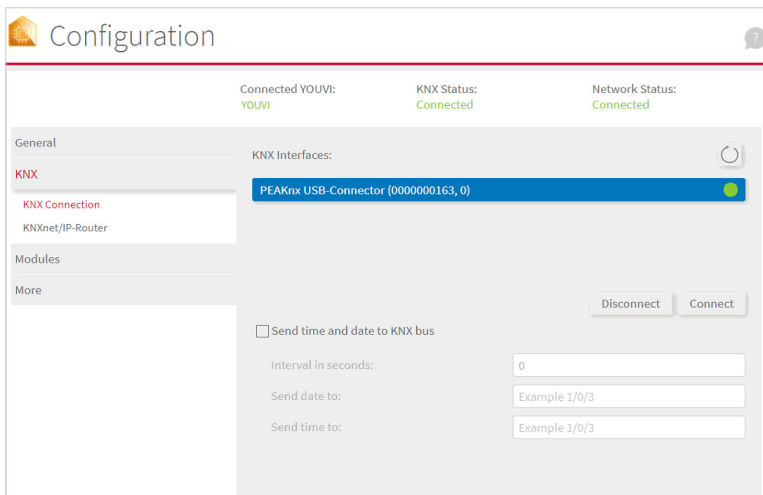

9 Notes on the bus monitor and IP router

The bus monitor and IP router need no further configuration and are ready for immediate use. The bus monitor for displaying and processing bus telegrams can be accessed via the *Dashboard* page in **YOUVI Configuration**. The IP router controls the communication between the KNX bus and the connected devices in your LAN (computers, tablets, smartphones). It can be found in the menu item *KNX > KNXnet/IP-Router*.

Note: *If you want to operate more than one KNX/IP router in the same KNX network, the multicast addresses must be different. If they both communicate over the same multicast address, this will result in a circulating message.*

10 Saving the YOUVI project

- In YOUVI Configuration on the *General > General* page you will find the item “YOUVI server Backup.” Click on the “Backup” button. The central backup is created and placed in the “Downloads“ folder.
- Create a folder for your backup files and move the backup file to this folder.

11 Technical support

If you experience problems with your Home Automation Server, please contact our PEAKnx Support Team:

- Mail: support@peaknx.com
- Create a Support Ticket: helpdesk.peaknx.com
- Phone: +49 6151 279 1825

12 Technical data

Computer system	
Processor	4x ARM-Cortex A76
Memory (RAM)	4 GB
Storage space	32 GB Flash

Ports	
USB	1 x USB-A
Ethernet	1 Gbit-Ethernet port, suitable standard for cabling: CAT5e
Fieldbus	1 x KNX
Supply	8-30 V DC; Reverse polarity protection
Power consumption	Peak load 10 W

Dimensions	
Size of the Server	4 TE; 72 x 90 x 60 mm
Weight of the Server	ca. 300 g

Environment	
Ambient temperature	0 - 60 °C
Protection rating (DIN EN 60529)	IP20
Protection class	3

Subject to change without notice

Content changes in this documentation, which serve the technical progress, are made without prior notice. This documentation has been prepared with great care and will be revised at regular intervals. Nevertheless, we cannot guarantee complete accuracy. All known errors are eliminated in new editions. For any indication of errors in this documentation, we are always grateful.

Conformity

Conformity is confirmed by the attached CE label.
The complete declaration of conformity can be found on the following page.

Disposal notes

Do not dispose the old device in the household waste!
Observe the EU Directive 2012/19/EU on environmentally friendly disposal of used electrical/ electronic equipment.

Waste of electrical and electronic equipment can

- contain hazardous substances that are harmful to health and the environment.
- contain valuable substances that are to be reused.

Therefore, do not dispose of with household waste.

Waste of electrical and electronic equipment can be returned to public collection points.



EU Declaration of Conformity



This declaration applies to the following product:

Product name: **Home Automation Server**

Item number(s): **PNX22-10004**

Manufacturer: **PEAKnx GmbH**

Leydheckerstrasse 10
64293 Darmstadt
Germany

CE We declare under our sole responsibility that the mentioned product is in conformity with the following directives and the affiliated harmonized standards:

EU Directive 2011/65/EU (RoHS 2) + 2015/863/EU (amended list of restricted substances)

Electromagnetic Compatibility

- DIN EN 55032:2022-08; VDE 0878-32:2022-08
- DIN EN 61000-4-2:2009-12; VDE 0847-4-2:2009-12
- DIN EN IEC 61000-4-3: 2021-11; VDE 0847-4-3:2021-11
- DIN EN 61000-4-4:2013-04; VDE 0847-4-4:2013-04
- DIN EN 61000-4-5: 2019-03 ; VDE 0847-4-5:2021-04
- DIN EN 61000-4-6:2014-08; VDE 0847-4-6:2014-08

PEAKnx GmbH, Executive Management

A handwritten signature in black ink, appearing to read "L. Rohrmann".

Lorenz Rohrmann, 2026-04-27

www.peaknx.com